

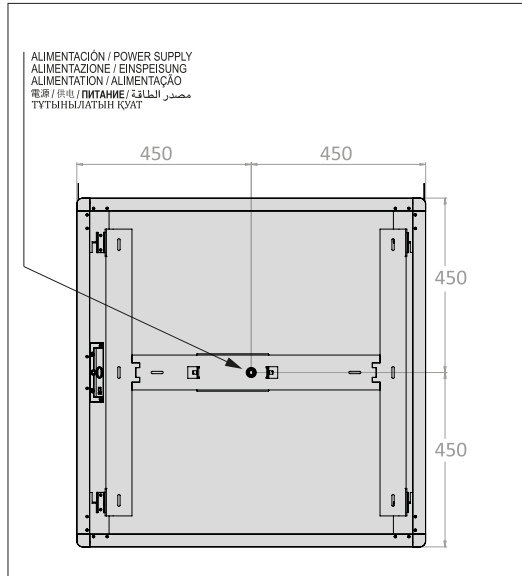

LAMPS

SUPERFLAT SURFACE 90X90



A LUMINAIRE INSTALLATION

INSTALACIÓN DE LA LUMINARIA / INSTALLAZIONE DELLA LAMPADA /  
 INSTALLATION DER BELEUCHTUNG / INSTALLATION DU LUMINAIRE /  
 INSTALAÇÃO DO APARELHO DE ILUMINAÇÃO / 照明器具の設置・据付け / 灯具的安装 / МОНТАЖ ОСВЕТИТЕЛЬНОГО ПРИБОРА /  
 ШАМДАЛДЫ ОРНАТУ / تركيب وحدة الإنارة

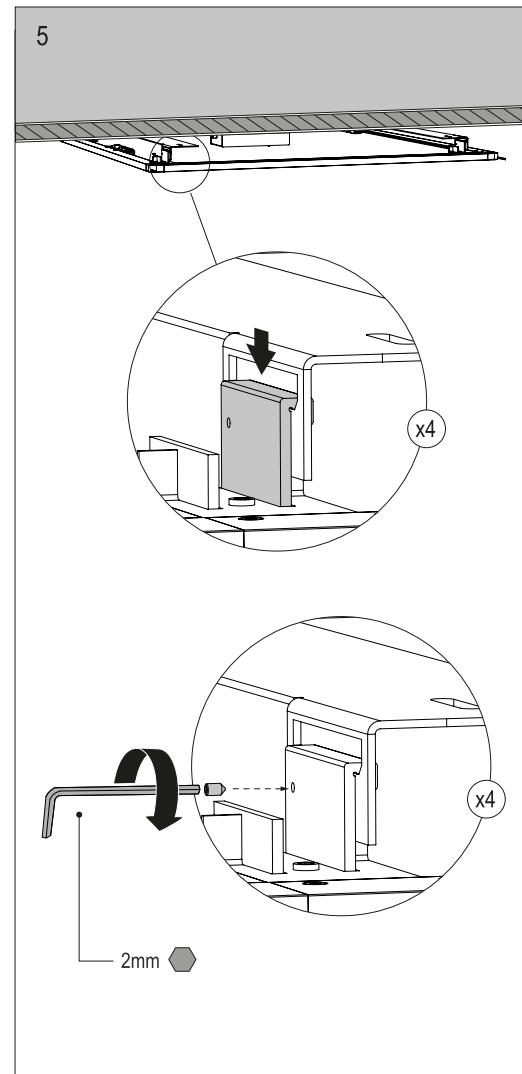
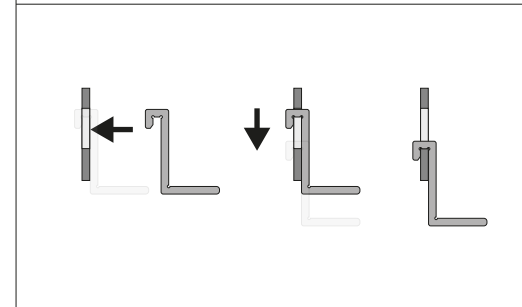
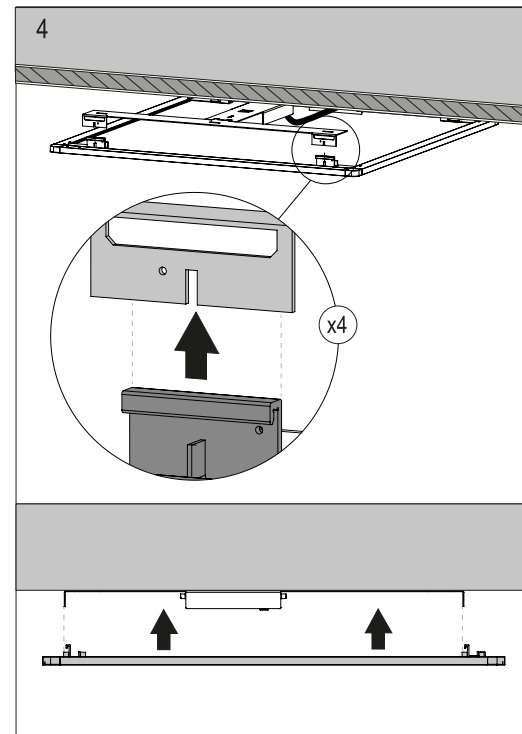
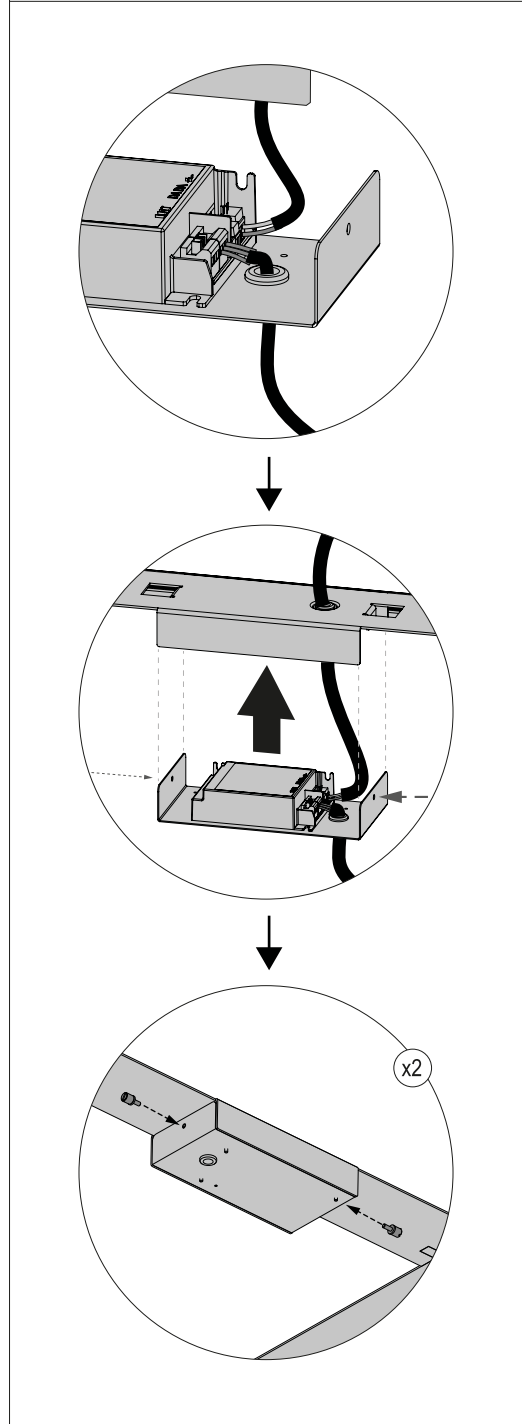
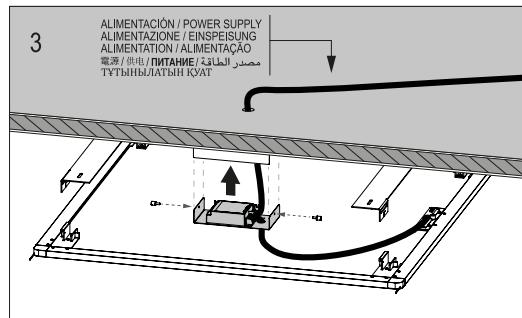
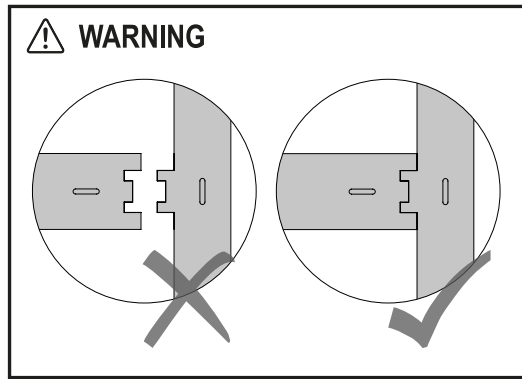
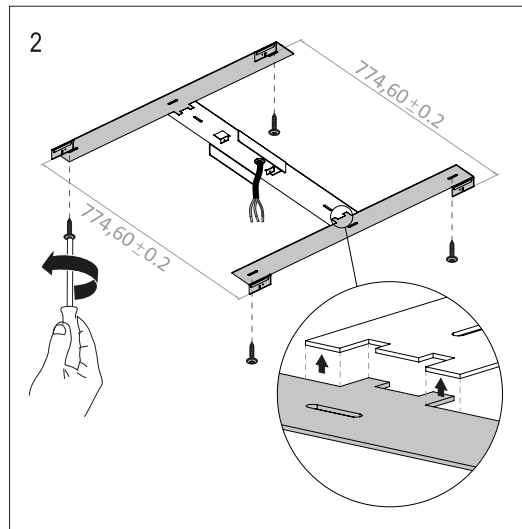
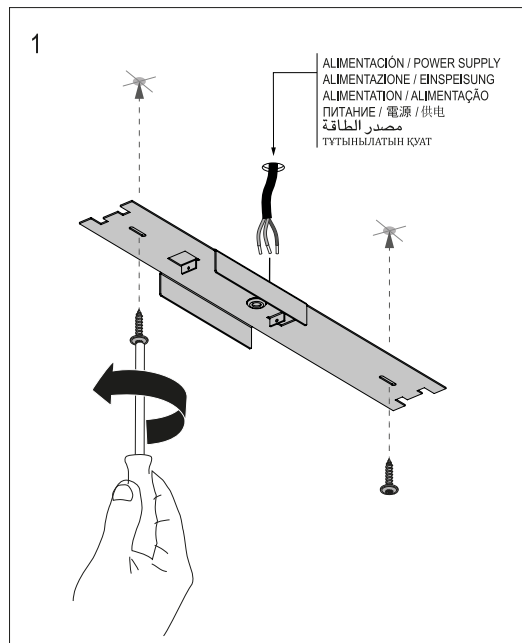

MORE THAN ONE MODULES IN LINE

