

TECHNICAL DATA

DATOS TÉCNICOS / DATI TECNICI / TECHNISCHE DATEN / DONNEES
TECHNIQUES / DADOS TÉCNICOS / テクニカルデータ / 技術数据 /
ТЕХНИЧЕСКИЕ ДАННЫЕ / ТЕХНИКАЛЫҚ МӨЛІМЕТТЕР / بيانات فنية

Reference				
03.4193	2700K	CR190	9,2W	698lm
03.4192	3000K	CR190	9,2W	810lm
03.4195	2700K	CR190	9,2W	698lm
03.4194	3000K	CR190	9,2W	810lm
03.4155	2700K	CR190	9,2W	698lm
03.4171	3000K	CR190	9,2W	810lm
03.4201	2700K	CR190	9,2W	698lm
03.4200	3000K	CR190	9,2W	810lm
03.4197	2700K	CR190	9,2W	698lm
03.4196	3000K	CR190	9,2W	810lm
03.4199	2700K	CR190	9,2W	698lm
03.4198	3000K	CR190	9,2W	810lm
03.4210	-	-	-	-
03.4208	-	-	-	-
03.4211	-	-	-	-
03.4209	-	-	-	-
03.4160	-	-	-	-
03.4212	-	-	-	-
03.4162	-	-	-	-
03.4213	-	-	-	-
03.4220	-	-	-	-
03.4218	-	-	-	-
03.4221	-	-	-	-
03.4219	-	-	-	-

A ELECTRICAL CONNECTION

CONEXIÓN ELÉCTRICA / CONNESSIONE ELETTRICA / ELEKTRISCHER ANSCHLUSS / CONNEXION ÉLECTRIQUE / LIGAÇÃO ELÉCTRICA / のコネクション / 电力连接 / ЭЛЕКТРИЧЕСКОЕ ПОДКЛЮЧЕНИЕ / ЭЛЕКТРЛИК БАЙЛАНЫС / التوصيل الكهربائي

QR-CBC-51 / PAR16 Ref. 4150-4152

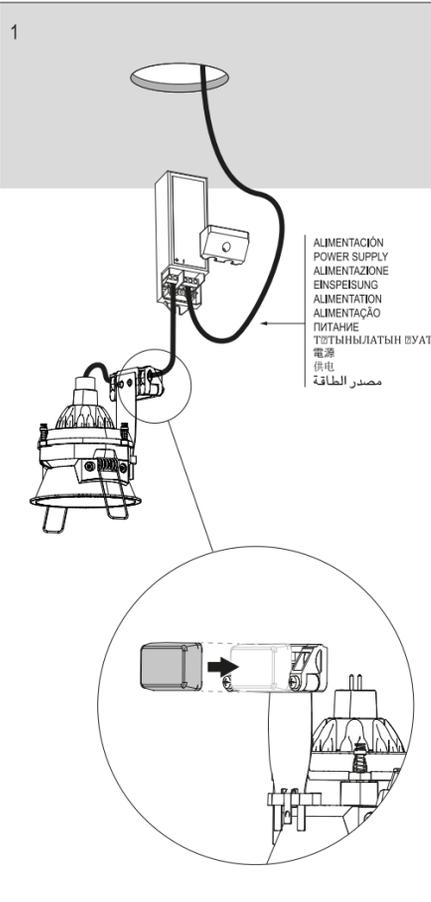

LED Ref. 4153-4158

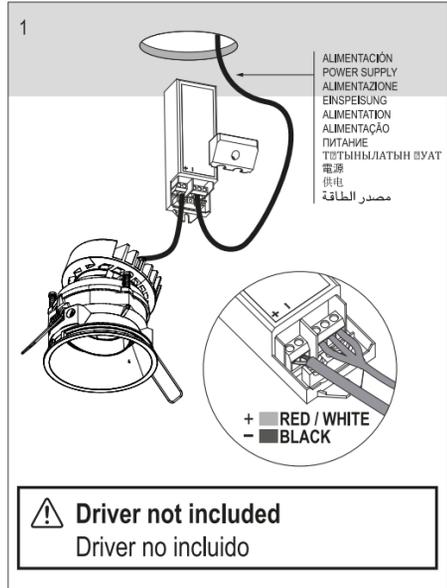

Driver not included
Driver no incluido

B RECESSING DIMENSIONS

DIMENSIONES DE EMPOTRAMIENTO / DIMENSIONI / EINBAUABMESSUNGEN / DIMENSIONS D'ENCASTREMENT / DIMENSÕES DO LUMINARI / 取り付けの寸法 / 嵌入的体积 / РАЗМЕРЫ ДЛЯ ВСТРАИВАНИЯ / ИМЕК ЖЕРЛЕРІНІҢ ӨЛШЕМДЕРІ / ابعاد التركيب الحائطي

Reference	Ø (mm)	C (mm)	F (mm)
03.4193	Ø75	75	91
03.4192	Ø75	75	91
03.4195	□75	75	93
03.4194	□75	75	93
03.4155	Ø75	75	90
03.4171	Ø75	75	90
03.4201	□75	75	90
03.4200	□75	75	90
03.4197	Ø75	75	81
03.4196	Ø75	75	81
03.4199	□75	75	81
03.4198	□75	75	81
03.4210	Ø75	75	130
03.4208	□75	75	130
03.4211	Ø75	75	155
03.4209	□75	75	155
03.4160	Ø75	75	130
03.4212	□75	75	130
03.4162	Ø75	75	155
03.4213	□75	75	155
03.4220	Ø75	75	120
03.4218	□75	75	120
03.4221	Ø75	75	140
03.4219	□75	75	140
03.4255	Ø75	75	91
03.4256	Ø75	75	91

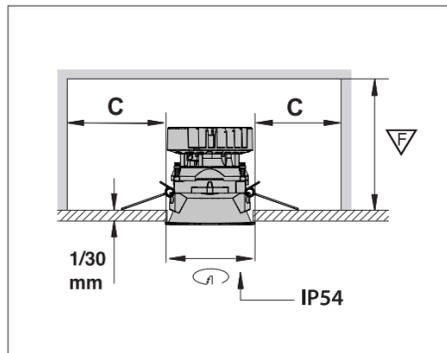

C LUMINAIRE INSTALLATION

INSTALACIÓN DE LA LUMINARIA / INSTALLAZIONE DELLA LAMPADA /
INSTALLATION DER BELEUCHTUNG / INSTALLATION DU LUMINAIRE /
INSTALAÇÃO DO APARELHO DE ILUMINAÇÃO / 照明器具の設置・据付け /
灯具的安装 / МОНТАЖ ОСВЕТИТЕЛЬНОГО ПРИБОРА /
ШАМДАЛДЫ ОРНАТУ / تركيب وحدة الإنارة

TRIM

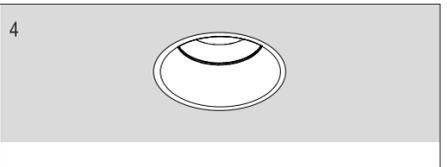
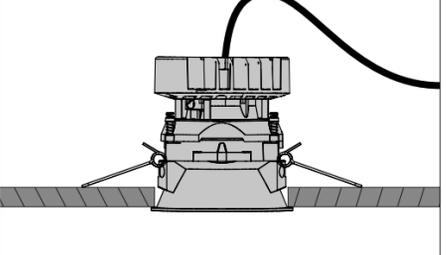
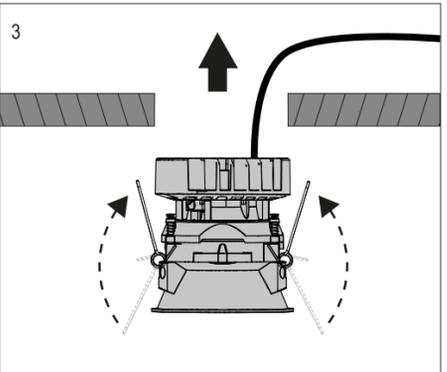
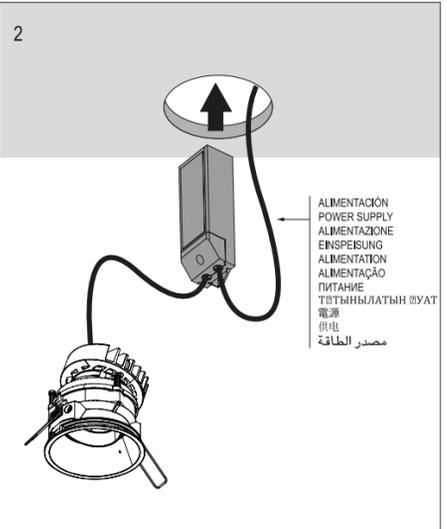
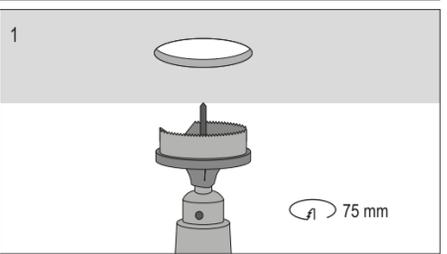

D ACCESSORIES

ACCESORIOS / ACCESSORI / ZUBEHÖR / ACCESSOIRES /
ACCESSÓRIOS / アクセサリー / 配件 / АКЦЕССУАРЫ /
КЕРЕК-ЖАРАҒАТАР / السجوريات

Not available for IP65 Version
No disponible para la versión IP65

LENS

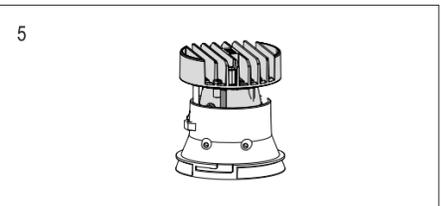
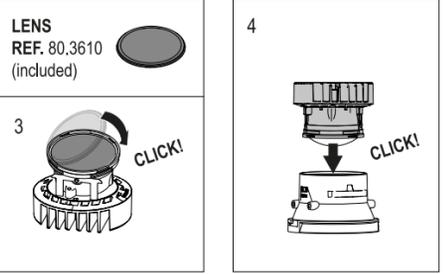
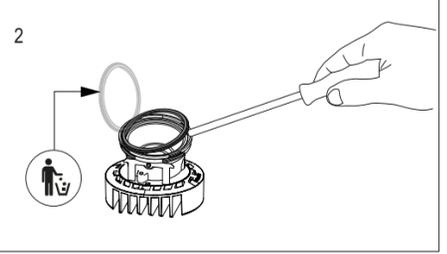
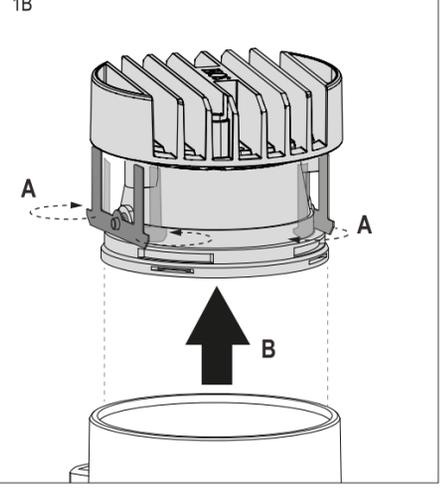
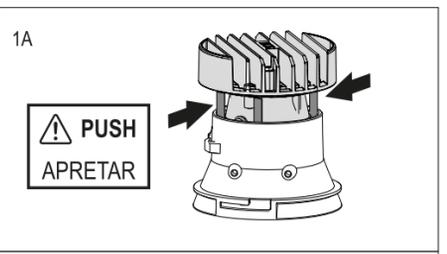

E LAMP CHANGE

CAMBIO DE LÁMPARA / CAMBIO DELLA LAMPADA / LAMPENWECHSEL /
CHANGEMENT DE L'AMPOULE / SUBSTITUIÇÃO DE LÂMPADA /
ランプの交換 / 更換灯泡 / ЗАМЕНА ЛАМПЫ / ШАМДЫ АУЫСТЫРУ /
تغيير الللمبة

QR-CBC-51 / PAR16 Ref. 4150-4152

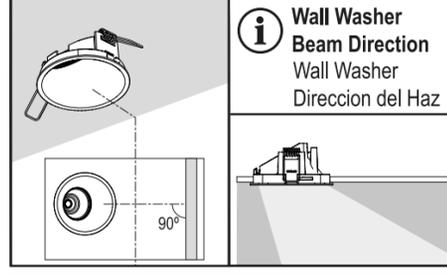
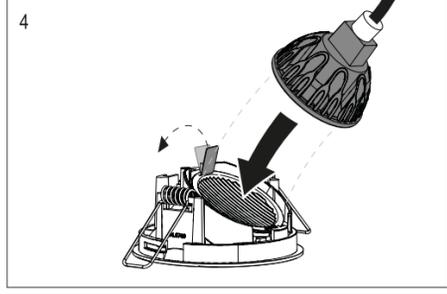
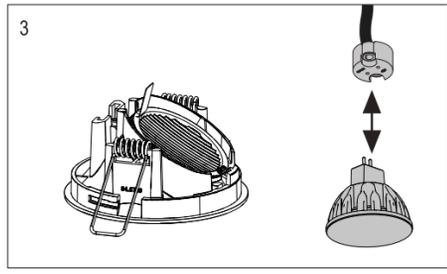
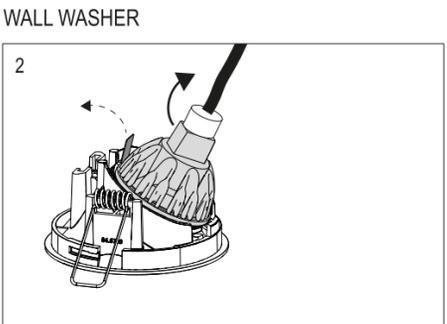
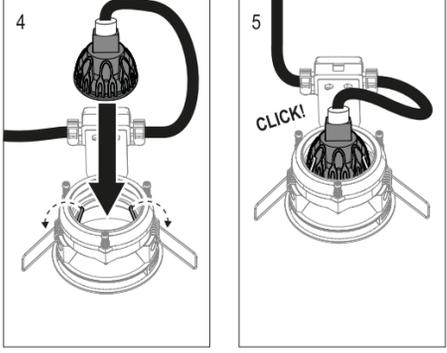
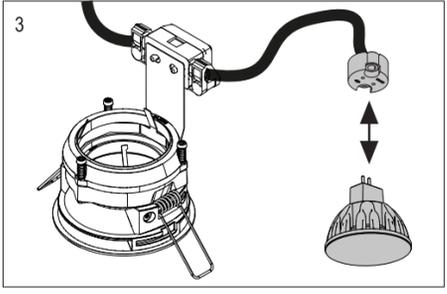
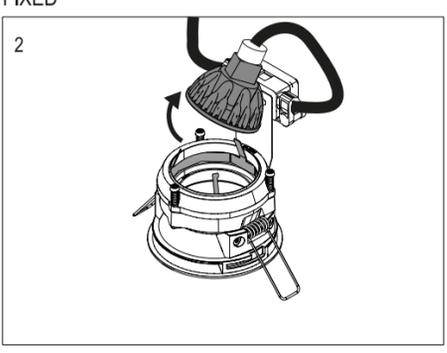
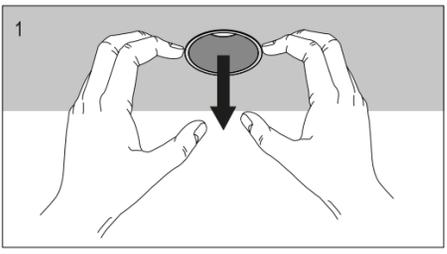

Wall Washer Beam Direction
Wall Washer
Direccion del Haz

LED DRIVER
≤ 60 Vout

ATTENTION / ATENCIÓN
The voltage under load does not exceed 25 V r.m.s. or 60 V ripple-free d.c. and the no-load voltage does not exceed 35 V peak or 60 V ripple-free d.c.
La tensión bajo carga no supera los 25 V r.m.s. o 60 V sin ondulaciones d.c. y la sin carga el voltaje no excede los 35 V pico o 60 V sin ondulaciones d.c.

WALL WASHER

