

TO AVOID SHADOWS IN THE CORNERS, INSTALL LED MODULES IN THE OPPOSITE DIRECTION AS SHOWN BELOW

USO 100 50, USO 140 90 & USO 900

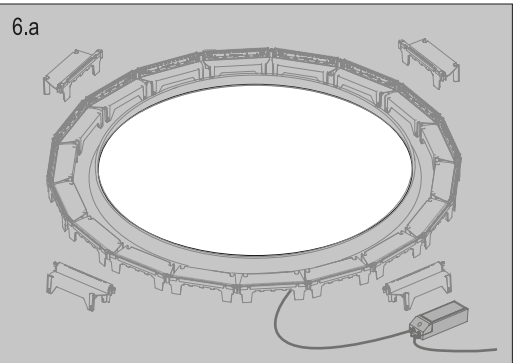

USO 1700

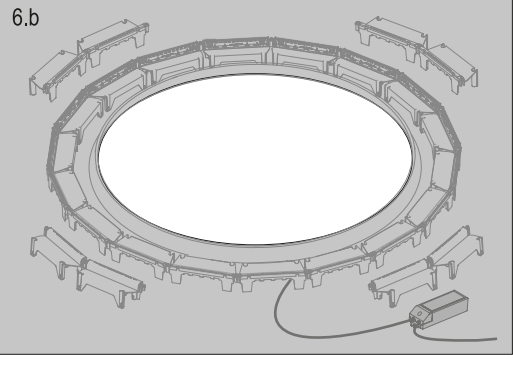

USO 2200 & USO 2500

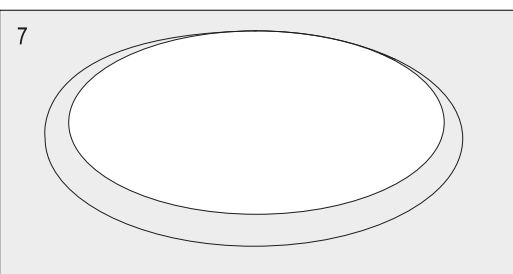
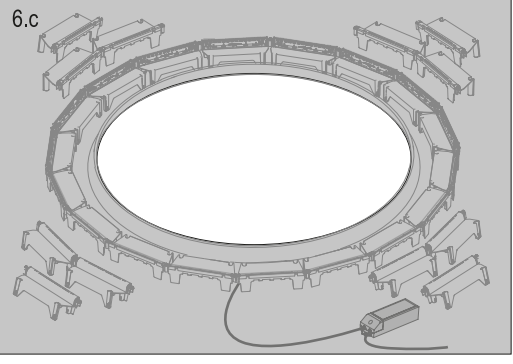

NOTE 1. Secondary connection detail

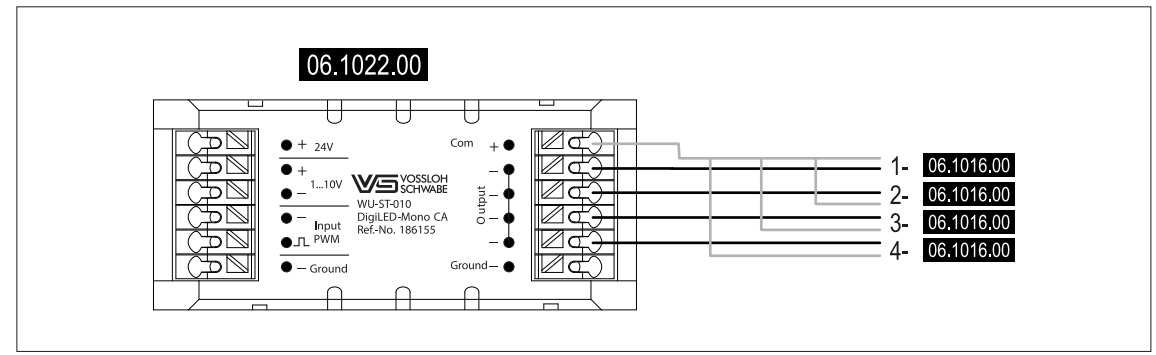

C CONNECTION DIAGRAM LED WHITE NOT DIMMABLE

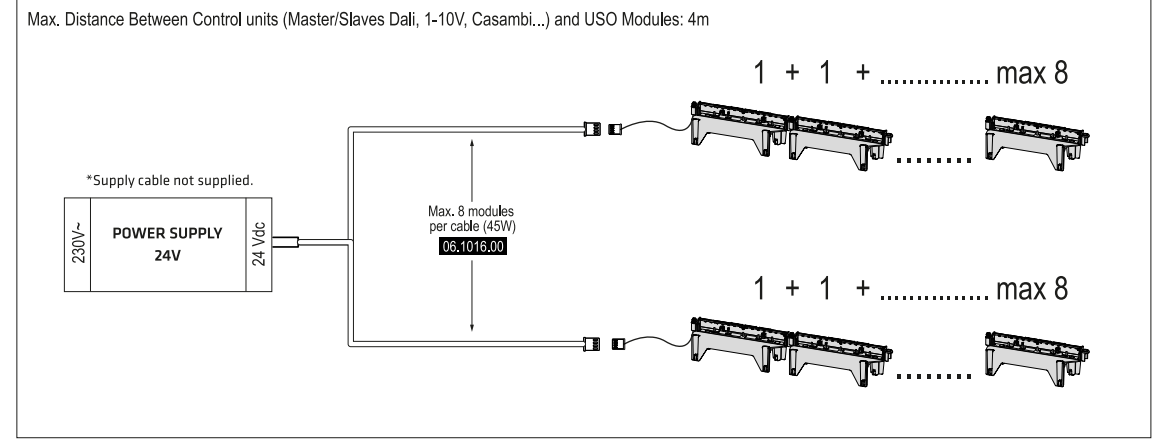

D CONNECTION DIAGRAM LED WHITE DIMMABLE 1-10V

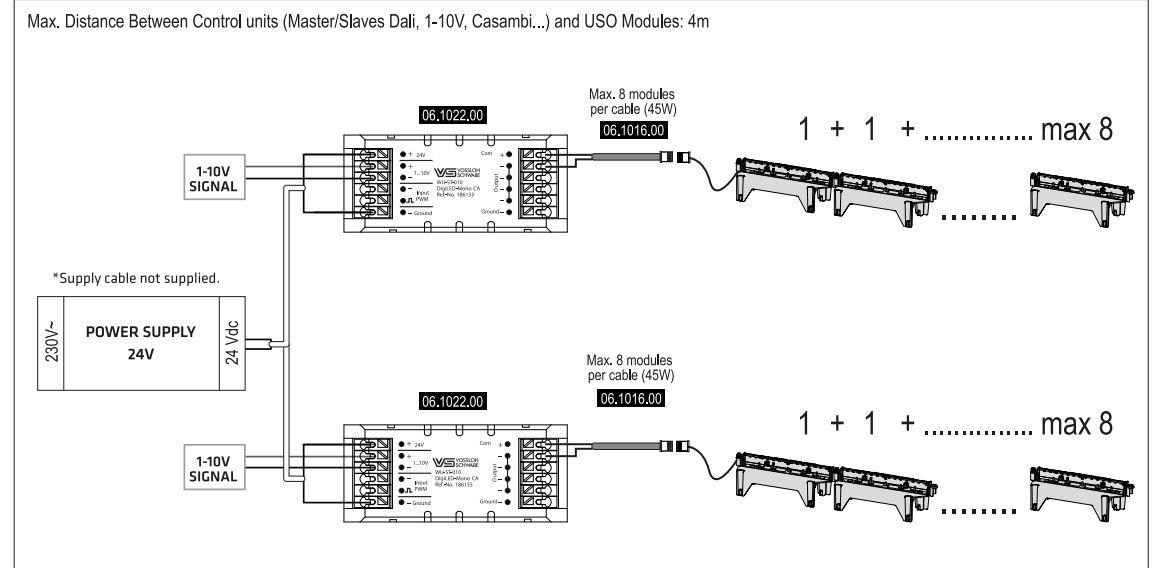

E CONNECTION DIAGRAM LED WHITE DIMMABLE DALI (USO 100 50, USO 140 90, USO 900)

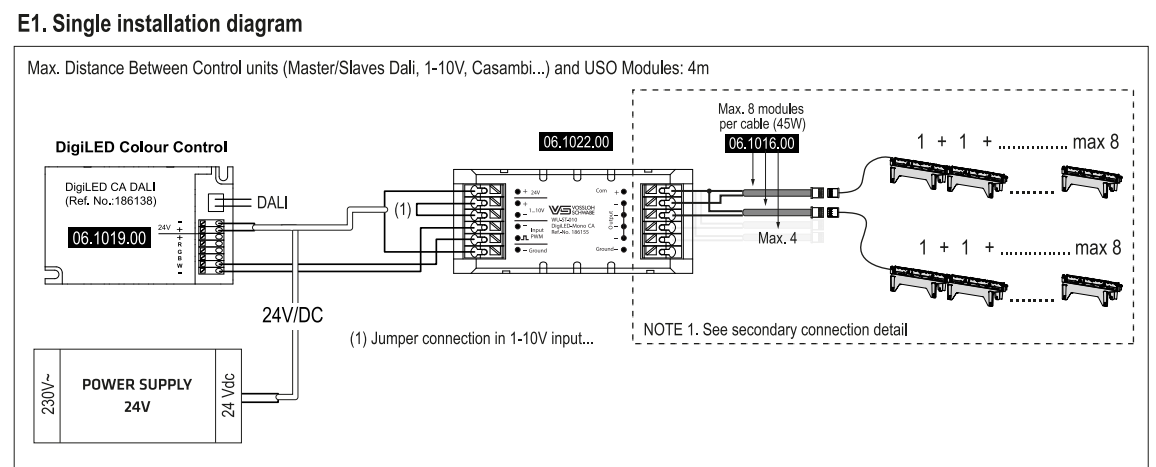

E2. Group installation diagram

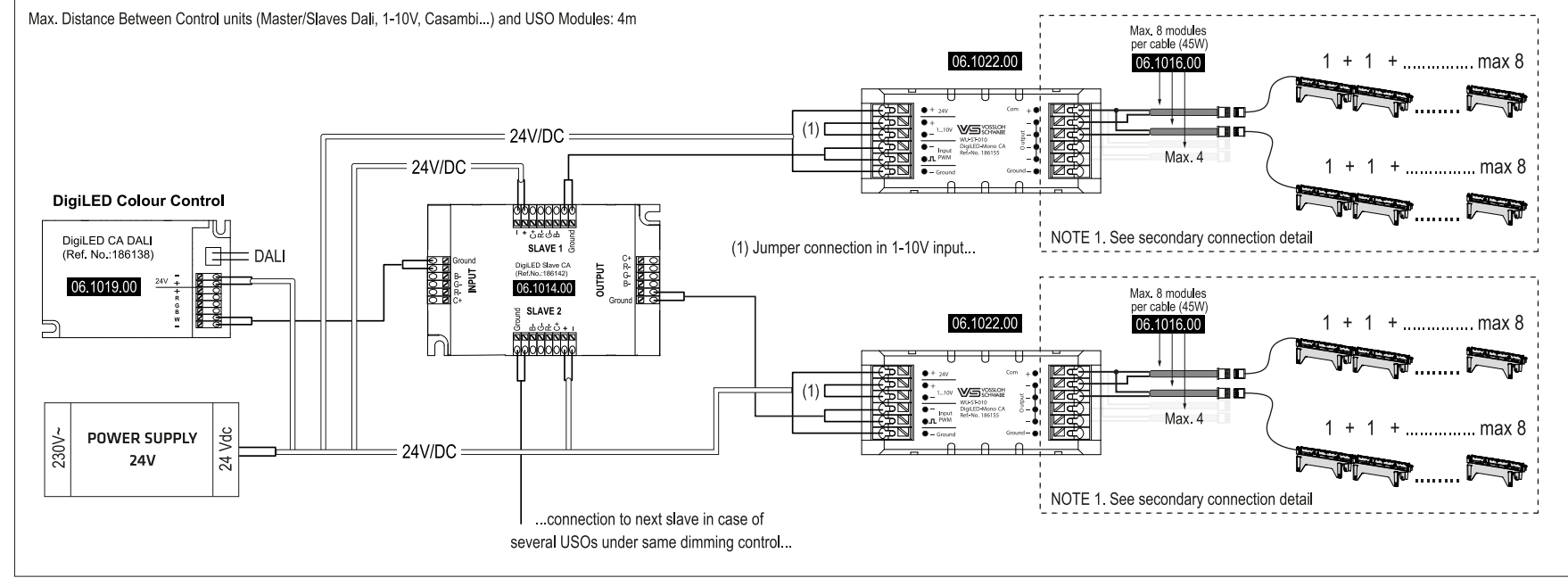

F CONNECTION DIAGRAM LED WHITE DIMMABLE DALI (USO 1700, USO 2200, USO 2500 or more than USO in the installation)

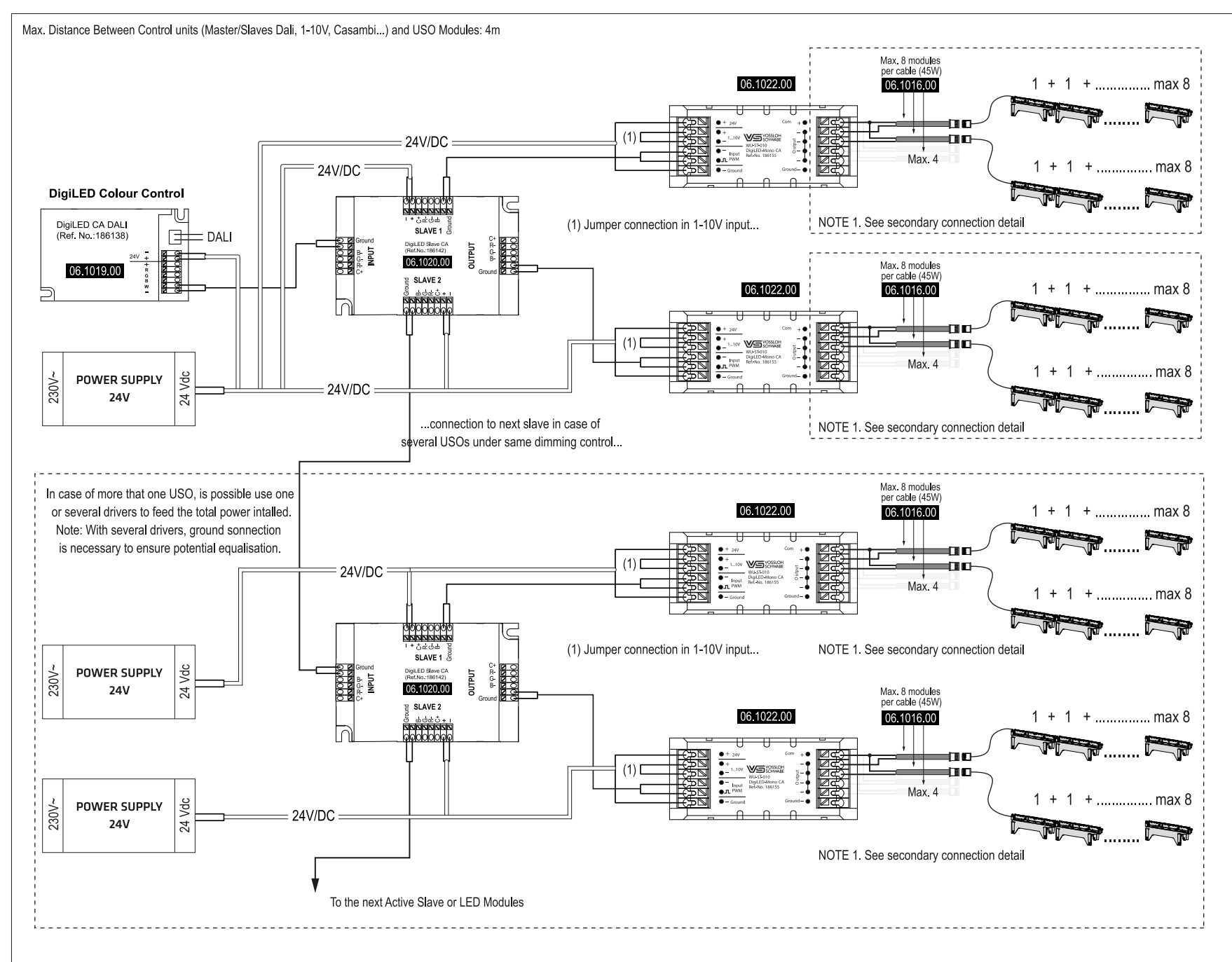

G CONNECTION DIAGRAM LED RGB (USO 100 50, USO 140 90, USO 900)

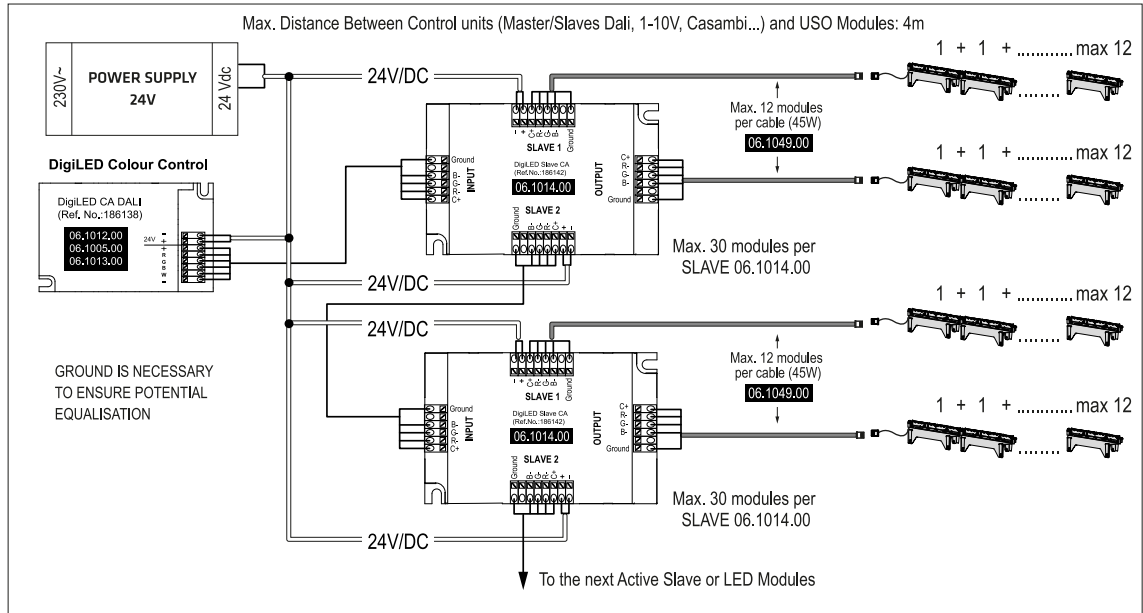

H CONNECTION DIAGRAM LED RGB (USO 1700, 2200, 2500)

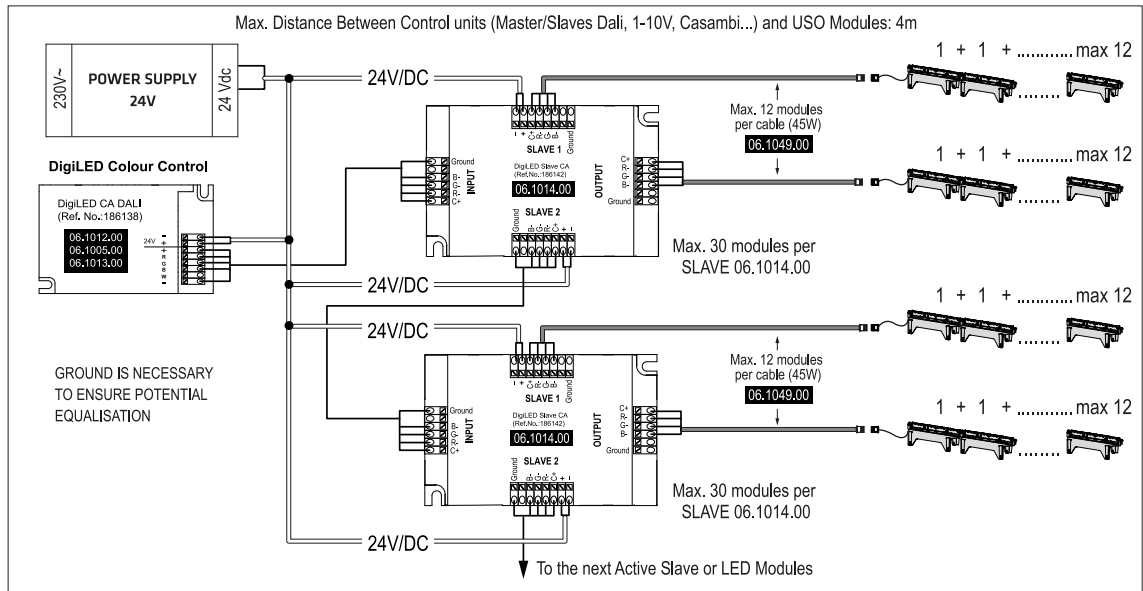

I CONNECTION DIAGRAM LED WHITE DIM CASAMBI

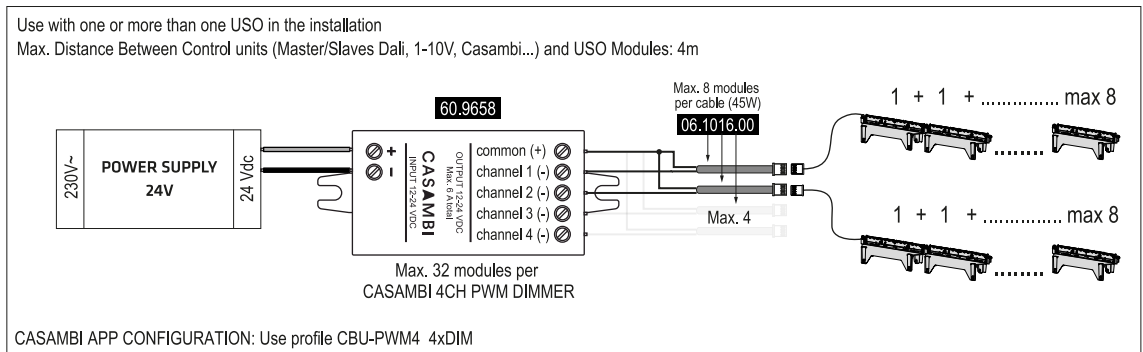

J CONNECTION DIAGRAM LED RGB DIM CASAMBI

