

Ref	Product name	Projector total weight	Connector max. Weight supported
03.221X.XX	Nano Spot	0,025 Kg	1,2 Kg
03.222X.XX	Micro Spot	0,030 Kg	1,2 Kg
03.223X.XX	Spot	0,072 Kg	1,2 Kg
03.224X.XX	Light Shadow Spot	0,074 Kg	1,2 Kg
03.225X.XX			
03.226X.XX	Light Stripe 300	0,026 Kg	1 Kg
03.227X.XX	Light Stripe 600	0,050 Kg	1 Kg
	Light Stripe 900	0,074 Kg	1 Kg
	Light Stripe 1200	0,096 Kg	1 Kg
	Light Stripe Wall Washer 300	0,026 Kg	1 Kg
03.228X.XX	Light Stripe Wall Washer 600	0,050 Kg	1 Kg
03.229X.XX	Light Stripe Wall Washer 900	0,074 Kg	1 Kg
	Light Stripe Wall Washer 1200	0,096 Kg	1 Kg

WARNING Only use with the electrical supply track system:
“ Micro Runing Magnet Track System ”

Ref	Track section max. Weight supported
06.6010	1,7 Kg
06.6011	2,55 Kg
06.6012	3,4 Kg

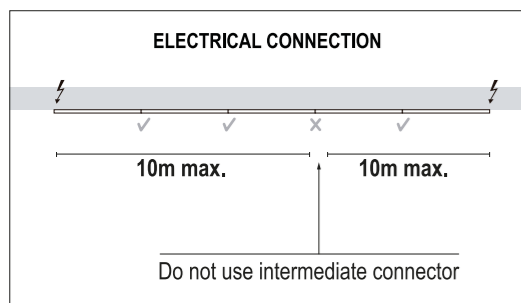
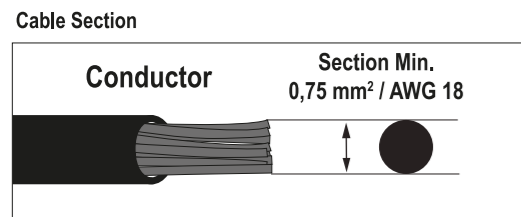

A LUMINAIRE INSTALLATION

INSTALACIÓN DE LA LUMINARIA / INSTALLAZIONE DELLA LAMPADA /
 INSTALLATION DER BELEUCHTUNG / INSTALLATION DU LUMINAIRE /
 INSTALAÇÃO DO APARELHO DE ILUMINAÇÃO / 照明器具の設置・据付け /
 灯具的安装 / МОНТАЖ ОСВЕТИТЕЛЬНОГО ПРИБОРА /
 ШАМДАЛДИ ОРНАТУ / تركيب وحدة الإنارة

1. SURFACE

FEED CONNECTOR

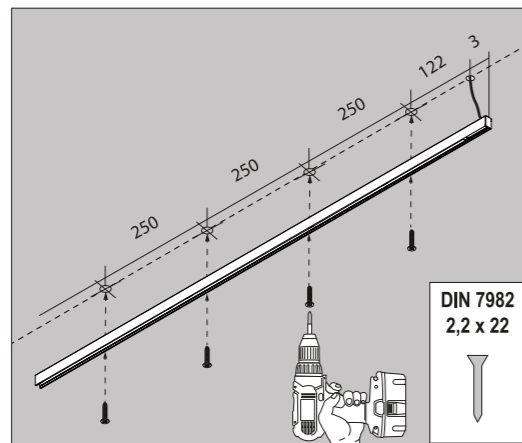
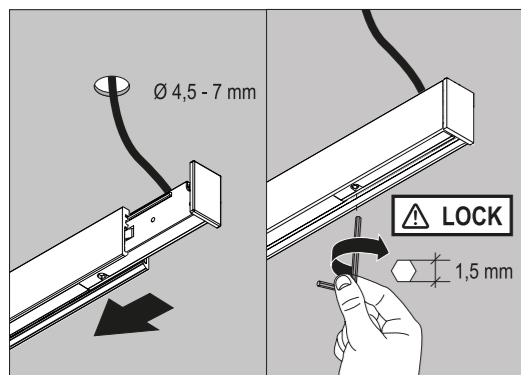

INTERMEDIATE CONNECTOR

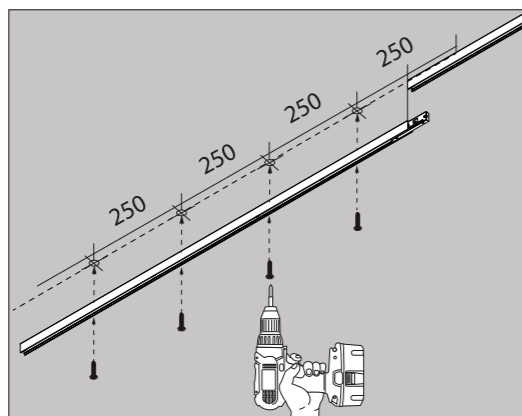
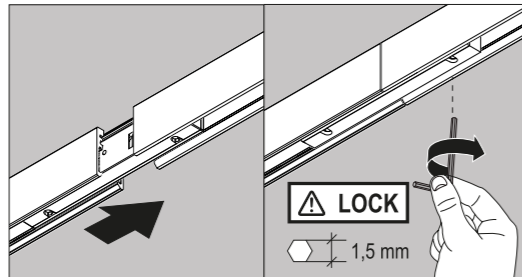
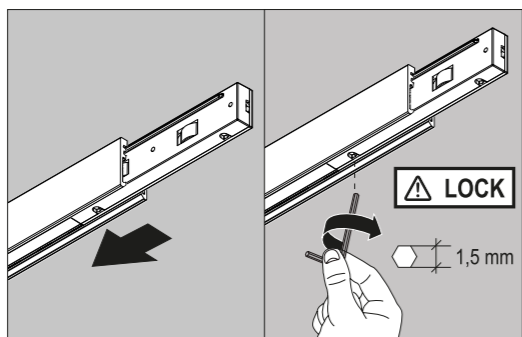

90° CORNER

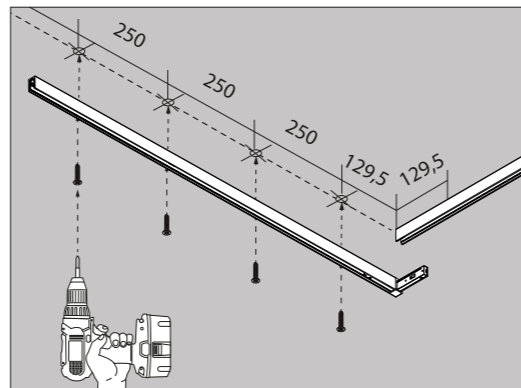
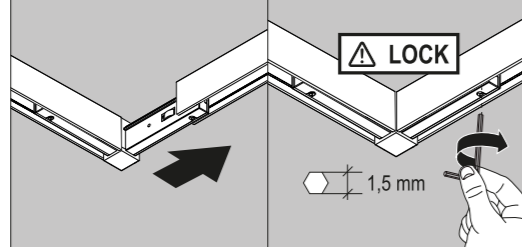
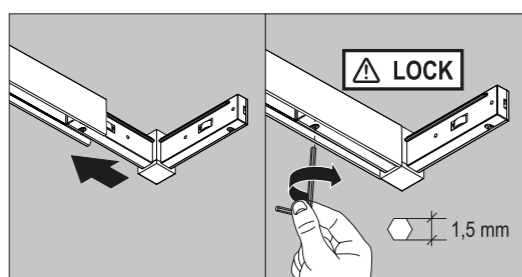

INNER CORNER

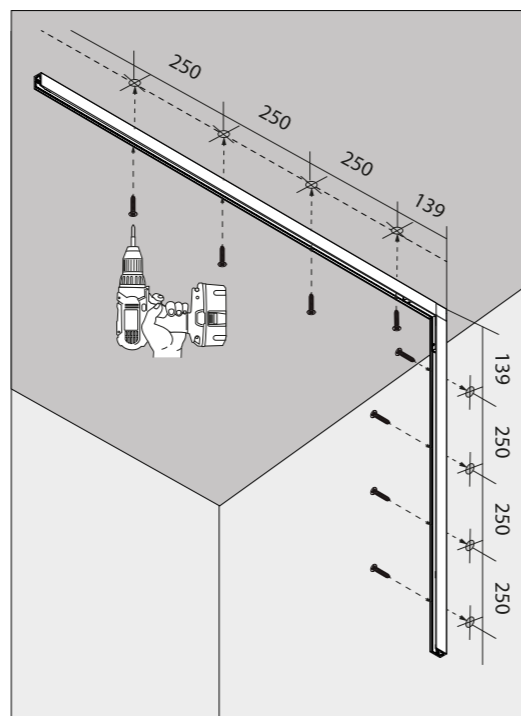
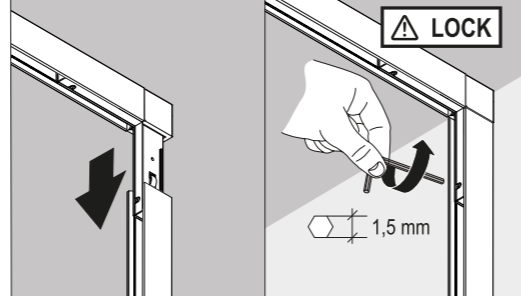
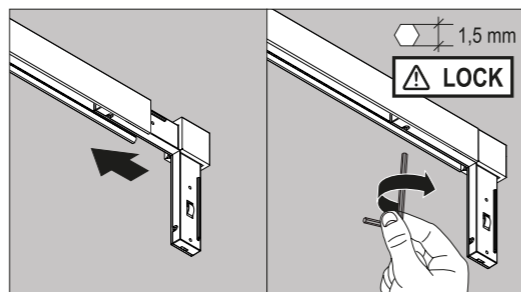

ENDCAP

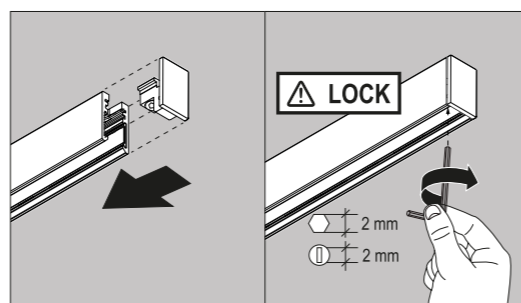

CUT PROFILE

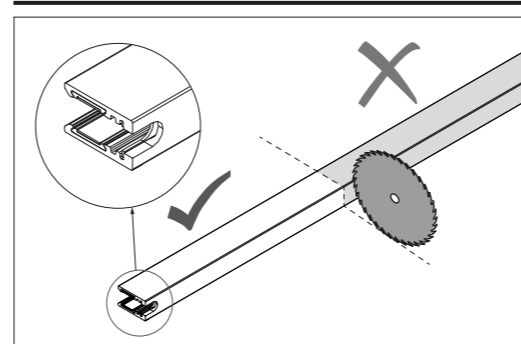

Use an abrasive cutting disc for steel.
 Thickness ≤ 1 mm

WARNING: After cutting the profile push both copper sheets to the inner part to avoid the contact with the adjacent profile

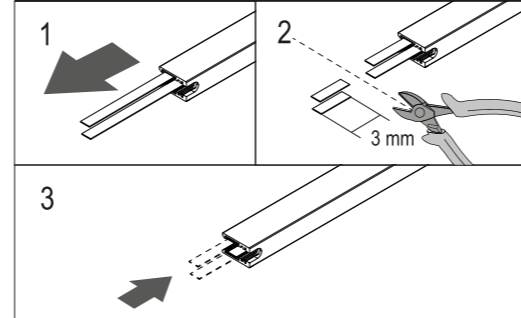

PUSH DIMMER CONNECTION (60.9394)

